

NEW



Connector for Internal Serial Transmission

CONNECTOR

MB-0153-2

October 2008

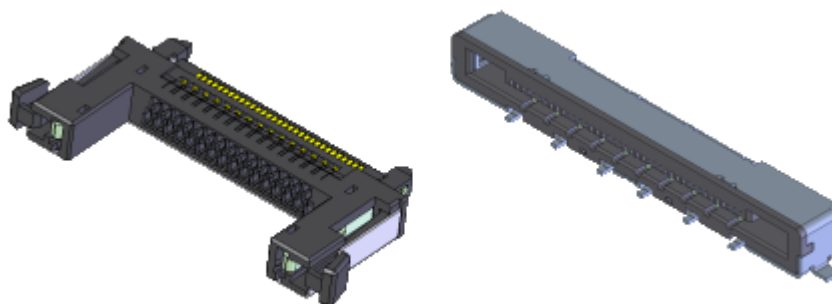
FI-R Series

RoHS Compliant

High-speed serial transmission such as LVDS, TMDS (HDMI), and PCI Express are widely used in applications in a variety of markets including the personal computer, TV, consumer device, copier, and medical device markets.

In these applications connectors not only need to have the ability to transmit signals at high speed, but they also must have the durability, ease of mating, and variety of options to respond to the demands of all designs.

The FI-R is the ideal connector series to meet these demands.

Features

- 0.5mm terminal pitch, 3.8mm connector, compact design with 21, 31, 41, and 51 positions.
- Stable mating with large mating guides on the Plug.
- Strong PCB retention with solder hold-downs on the Receptacle.
- Impedance matching: 100 ohm. Ground reinforced by shell structure and hold-downs.
- Receptacle options include with and without shell, and right-angle and straight types, all with a common footprint.
- Mechanical lock to prevent mis-mating and accidental unmating.
- Plug options for discrete wire crimping, fine coaxial wire soldering, and FFC to suit a variety of needs.
- VESA standard connector for TV LCD interface.

General Specification

Receptacle

A1. FI-RE**S-HF (Right-angle, shell type)

A2. FI-RE**S-VF (Straight, shell type)

■ No. of Contacts: 21, 31, 41, 51pos.

■ Contact Resistance: 50m ohm max.

■ Dielectric Withstanding Voltage:
AC500Vr.m.s, 1 minute

■ Operating Temperature:
-40Deg. C to +80Deg. C

■ Rated Current:
AC, DC 0.8A each / terminal

■ Insulation Resistance: 100M ohm min.

■ Pitch: 0.5mm



Plug, Crimp Type

B1. FI-RE**HL (Mechanical lock, shell type)

B2. FI-RC3-1A-1E-15000 (Crimp for upper contact)

B3. FI-RC3-1B-1E-15000 (Crimp for lower contact)

■ No. of Contacts: 21, 31, 41, 51pos.

■ Contact Resistance: 50m ohm max.

■ Dielectric Withstanding Voltage:
AC500Vr.m.s, 1 minute

■ Operating Temperature:
-40Deg. C to +80Deg. C

■ Rated Current:
AC, DC 0.7A each / terminal

■ Insulation Resistance: 100M ohm min.

■ Pitch: 0.5mm

■ Applicable Cable: 30, 32, 36 AWG



Plug, Solder Type

C1. FI-RE**CL (Mechanical lock, shell type)

C2. FI-RE**CL-SH2-3000 (Cover shell for solder type)

■ No. of Contacts: 21, 31, 41, 51pos.

■ Contact Resistance: 50m ohm max.

■ Dielectric Withstanding Voltage:
AC500Vr.m.s, 1 minute

■ Operating Temperature:
-40Deg. C to +80Deg. C

■ Rated Current:
AC, DC 0.7A each / terminal

■ Insulation Resistance: 100M ohm min.

■ Pitch: 0.5mm

■ Applicable Cable:
Coaxial cable 40 AWG



Materials and Finishes

ReceptacleA1. FI-RE**S-HF (Right-angle, shell type)

Component	Material and Finish
Contact	Copper alloy / Contact area Au, SMT Terminal area Sn plating
Insulator	Heat resistant plastic / None
Shell	Stainless steel / None

A2. FI-RE**S-VF (Straight, shell type)

Component	Material and Finish
Contact	Copper alloy / Contact area Au, SMT Terminal area Sn plating
Insulator	Heat resistant plastic / None
Shell	Stainless steel / None

**Plug, Crimp Type**B1. FI-RE**HL (Mechanical lock, shell type)

Component	Material and Finish
Press Fit Shell	Copper alloy / Sn plating
Insulator	Heat resistant plastic / None
Lock Spring	Stainless steel / None

B2. FI-RC3-1A-1E-15000 (Crimp for upper contact)

Component	Material and Finish
Contact	Phosphor bronze / Contact area Au, Terminal area Sn plating

B3. FI-RC3-1B-1E-15000 (Crimp for lower contact)

Component	Material and Finish
Contact	Phosphor bronze / Contact area Au, Terminal area Sn plating



Materials and Finishes

Plug, Solder TypeC1. FI-RE**CL (Mechanical lock, shell type)

Component	Material and Finish
Contact	Copper alloy / Contact area Au, Terminal area Sn plating
Press Fit Shell	Copper alloy / Sn plating
Insulator	Heat resistant plastic / None
Lock Spring	Stainless steel / None

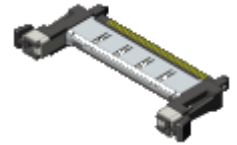
C2. FI-RE**CL-SH2-3000 (Cover shell for solder type)

Component	Material and Finish
Cover Shell	Stainless steel / None



Ordering Information

Receptacle (Right-angle, shell type)
Individual Connector (SJ102934)

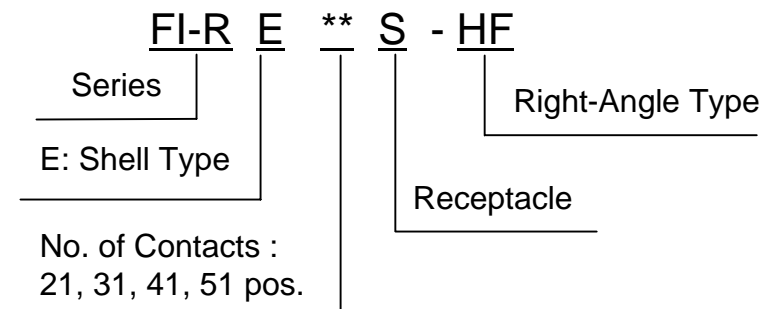

A1

Unit: mm

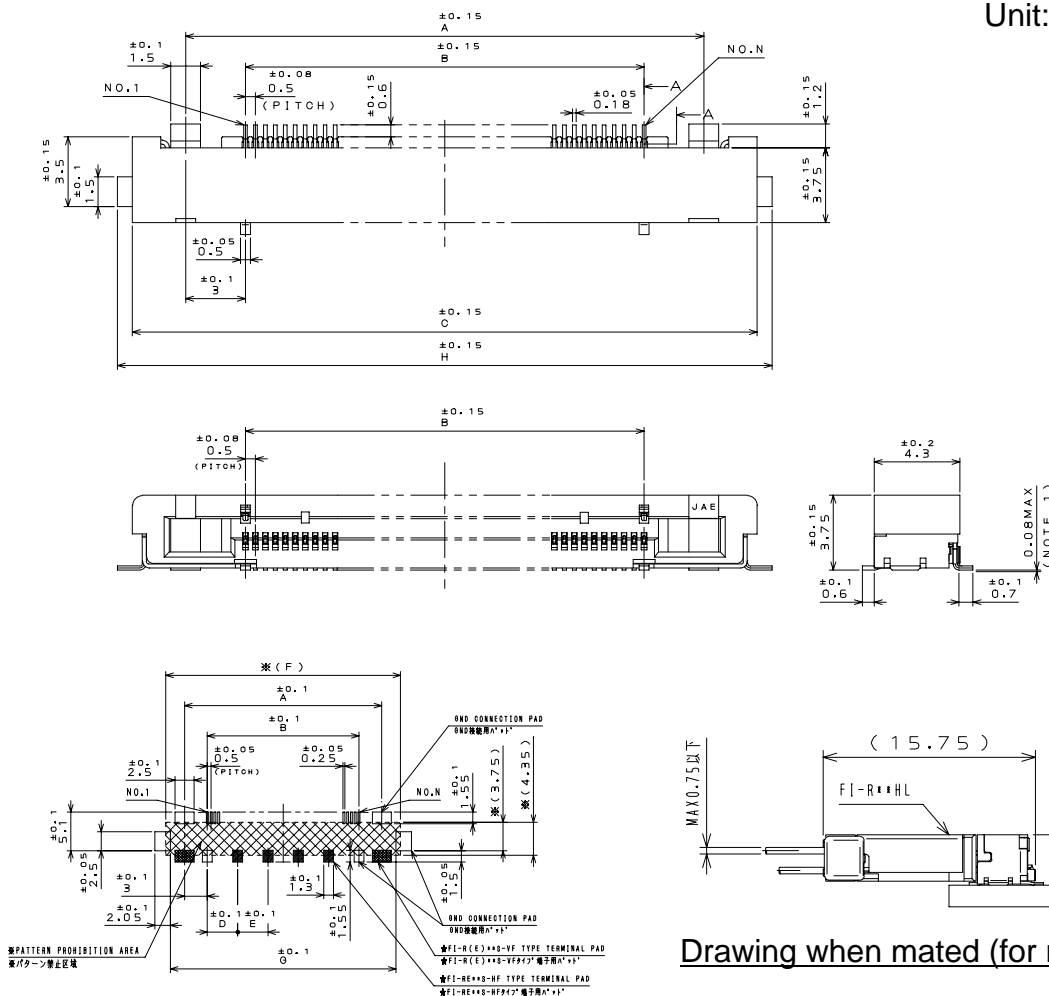

Drawing when mated (for reference)

Recommended board dimensions

Dimensions

NO.OF CONTACTS (N)	A	B	C	D	E	F	G	H
21	16	10	21.35	—	—	20.95	19.75	22.85
31	21	15	26.35	—	—	25.95	24.75	27.85
41	26	20	31.35	—	—	30.95	29.75	32.85
51	31	25	36.35	—	—	35.95	34.75	37.85

Ordering Information

Receptacle (Right-angle, shell type)
Embossed Tape Reel (SJ102937)

FI-R E ** S - HF - R1500

Series
E: Shell Type

No. of Contacts:
21, 31, 41, 51 pos.

Embossed Tape
1500pcs. per reel

Right-Angle Type

Receptacle



A1

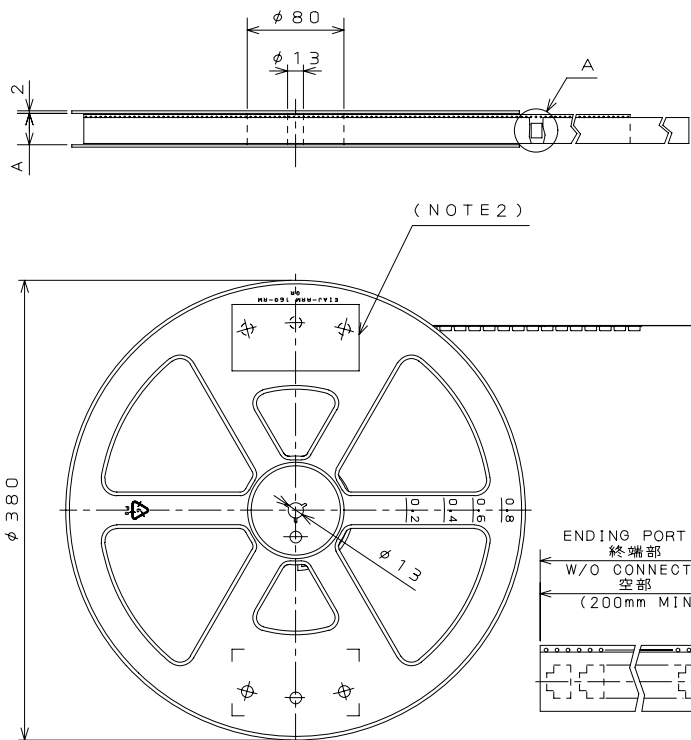

Dimensions

Unit: mm

NO.OF CONTACT	A	B	C	D	E
2 1	46	44	20.2	40.4	23.85
3 1	46	44	20.2	40.4	28.85
4 1	58	56	26.2	52.4	33.85
5 1	58	56	26.2	52.4	38.85

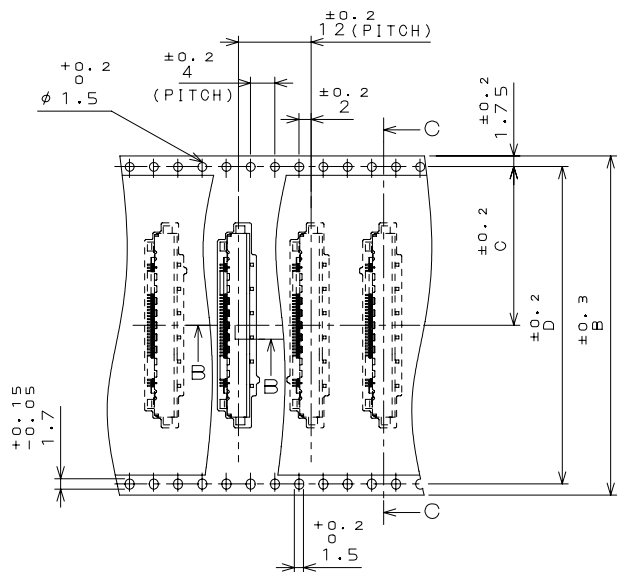
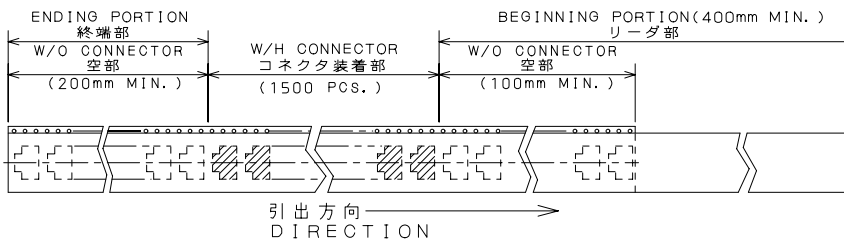

DETAIL A
A部詳細図
(SCALE 1:1)

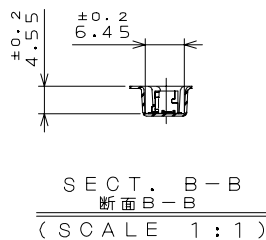

SECT. B-B
断面B-B
(SCALE 1:1)

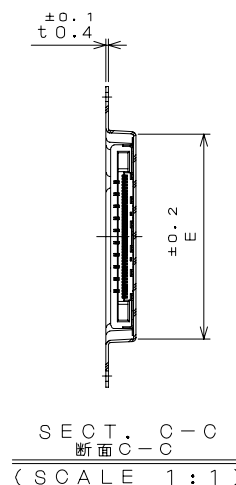

SECT. C-C
断面C-C
(SCALE 1:1)

Ordering Information

Receptacle (Straight, shell type)
Individual Connector (SJ102933)

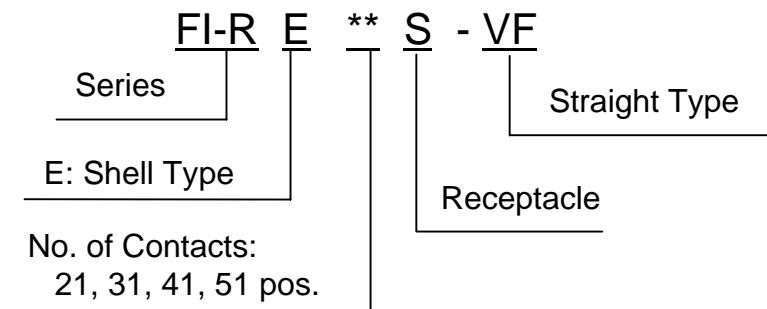

A2

Unit: mm

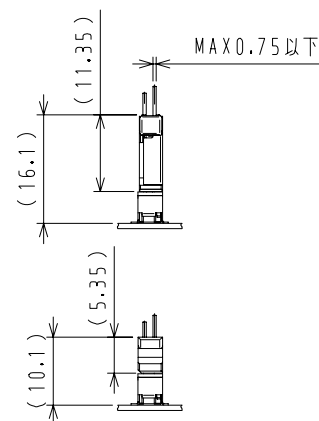
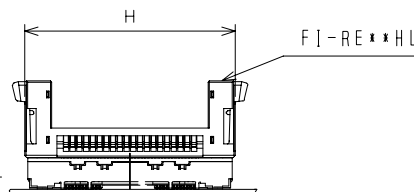
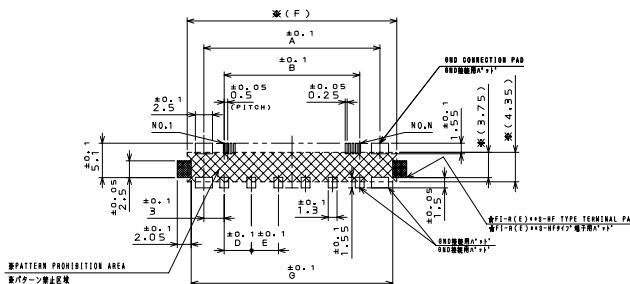
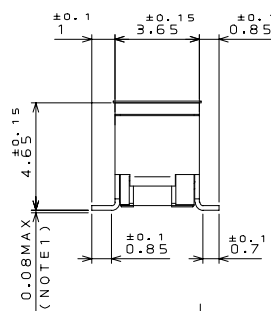
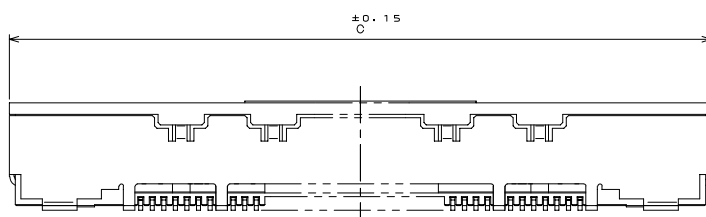
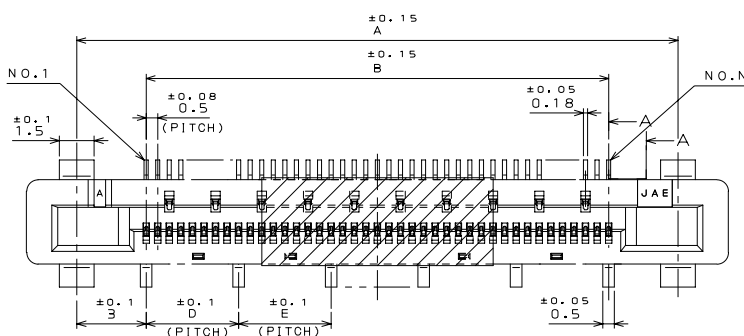

Recommended board dimensions

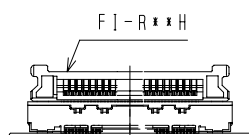

Drawing when mated (for reference)

Dimensions

NO.OF CONTACTS (N)	A	B	C	D	E	F	G	H
21	16	10	20.35	3	—	20.95	19.75	21.25
31	21	15	25.35	4	—	25.95	24.75	26.25
41	26	20	30.35	4	4	30.95	29.75	31.25
51	31	25	35.35	5	5	35.95	34.75	36.25

Ordering Information

Receptacle (Straight, shell type)
Embossed Tape Reel (SJ102936)

Series **FI-R E** **
E: Shell Type
No. of Contacts :
21, 31, 41, 51 pos.

S - VF - R1300
Embossed Tape
1300pcs. per reel
Straight Type
Receptacle



A2

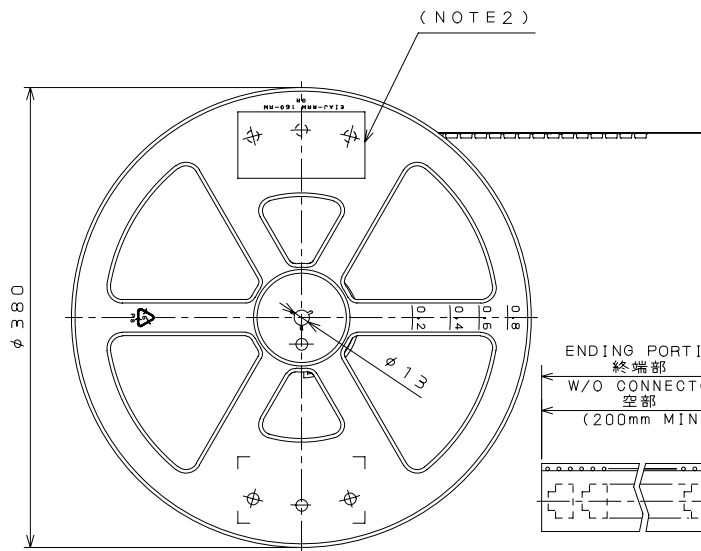
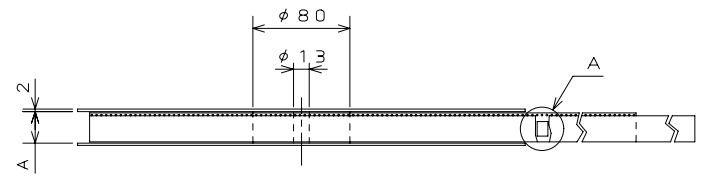

Dimensions

Unit: mm

NO.OF CONTACT	A	B	C	D	E
21	46	44	20.2	40.4	20.6
31	46	44	20.2	40.4	25.6
41	58	56	26.2	52.4	30.6
51	58	56	26.2	52.4	35.6

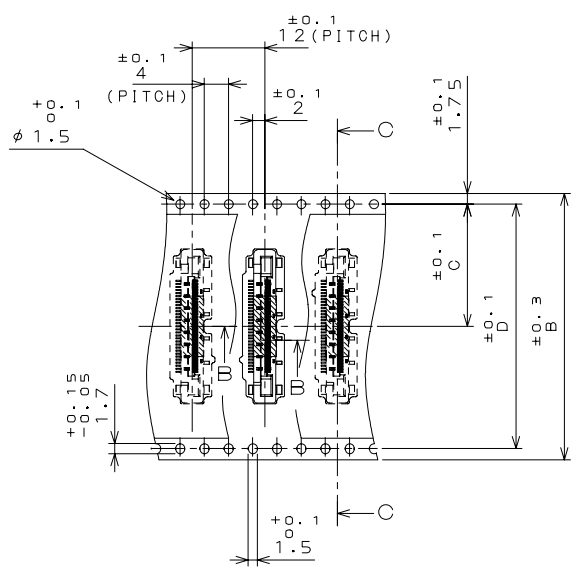
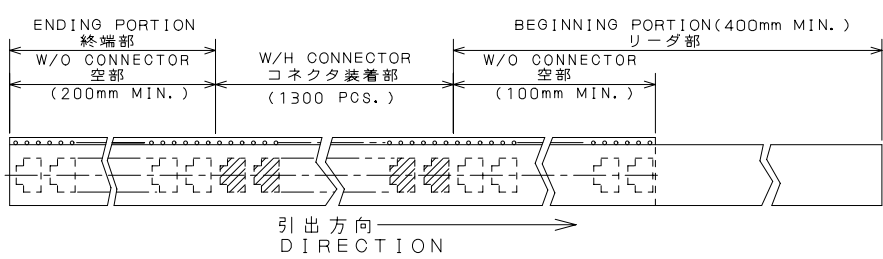

DETAIL A
A部詳細図
(SCALE 1:1)

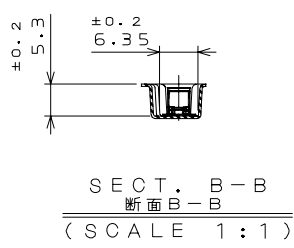

SECT. B-B
断面B-B
(SCALE 1:1)

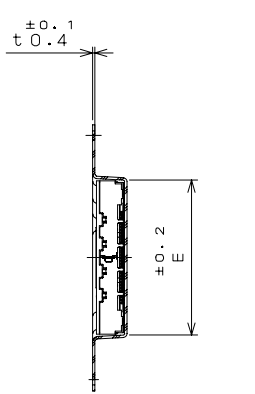

SECT. C-C
断面C-C
(SCALE 1:1)

Ordering Information

Plug, Crimp Type (Lock, shell type)
Individual Connector (SJ103279)

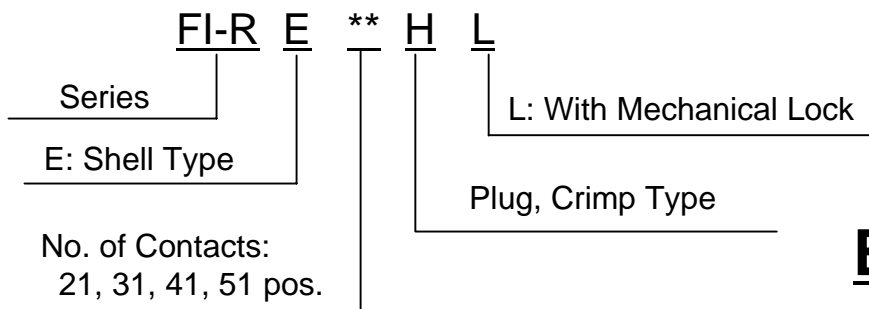

B1

Unit: mm

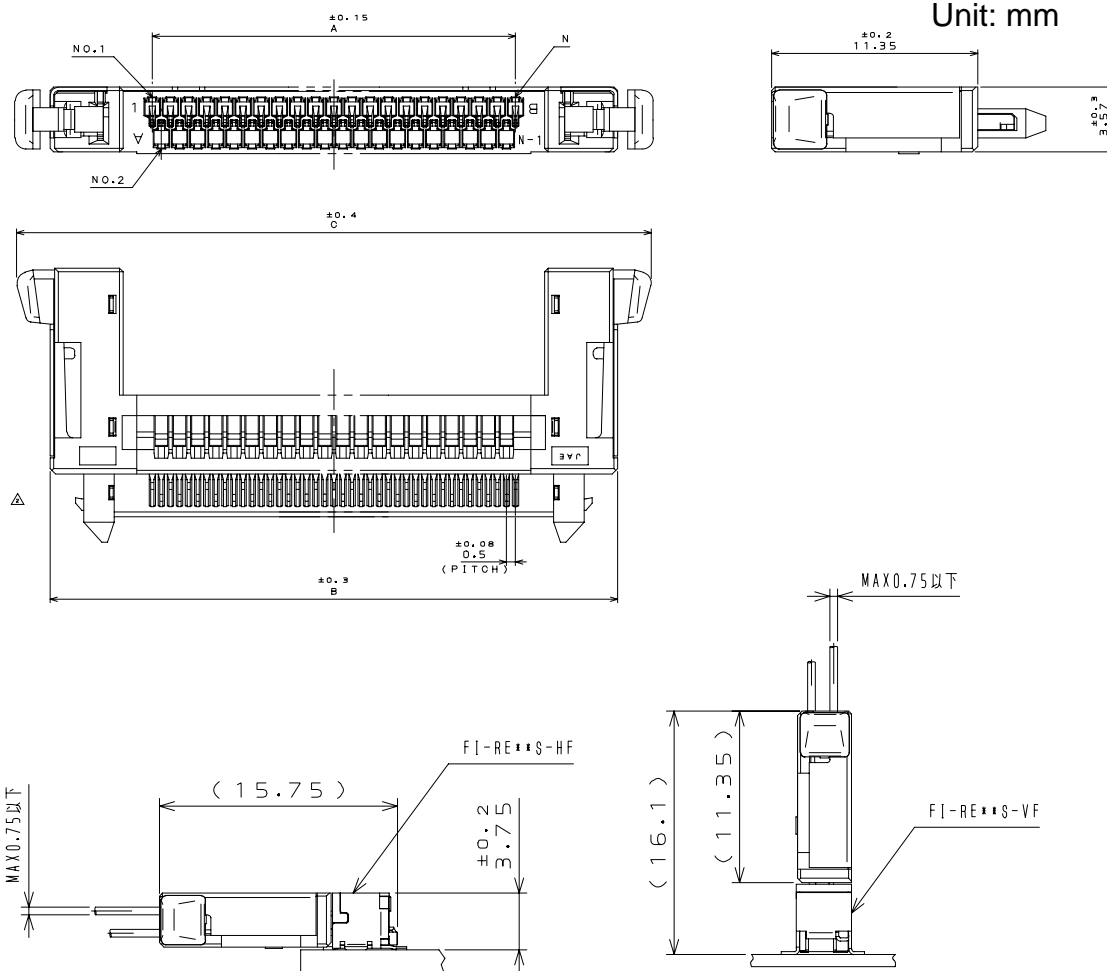

Drawing when mated (for reference)

Dimensions

NO.OF CONTACTS (N)	DEMENSION		
	A	B	C
21	10	21.25	24.95
31	15	26.25	29.95
41	20	31.25	34.95
51	25	36.25	39.95

Ordering Information

Upper Contact for Crimp Housing (SJ103060)

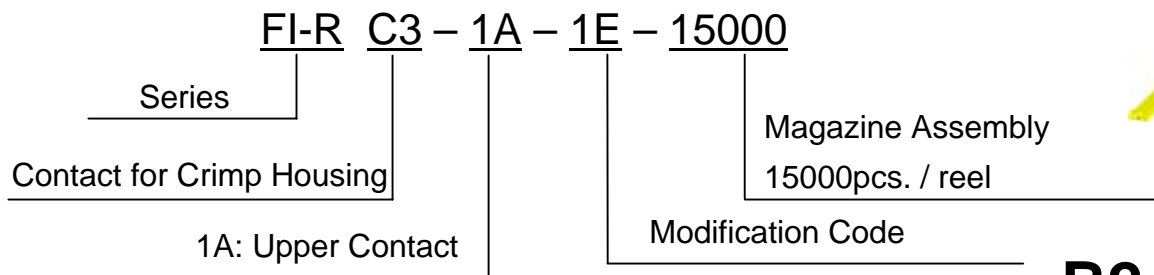

B2

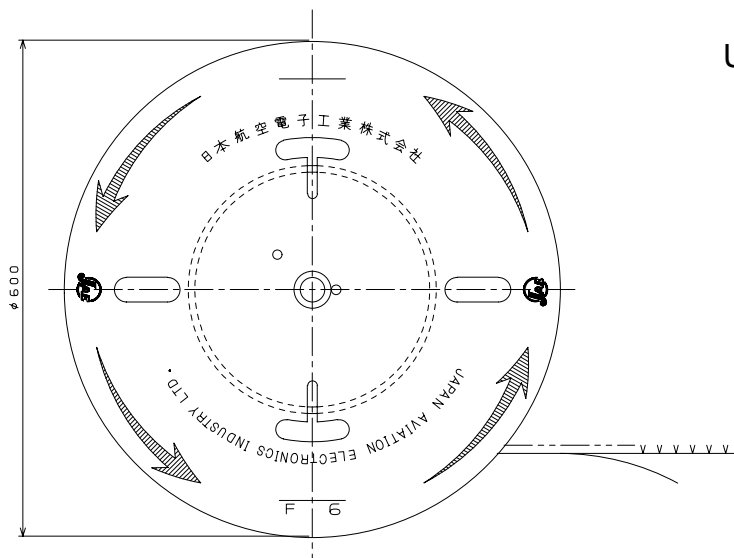
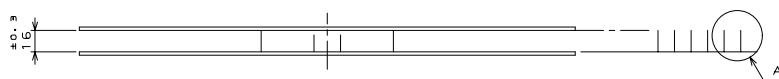

Unit: mm



EXCLUDING CRIMP POT
 クリンプポット部は除く

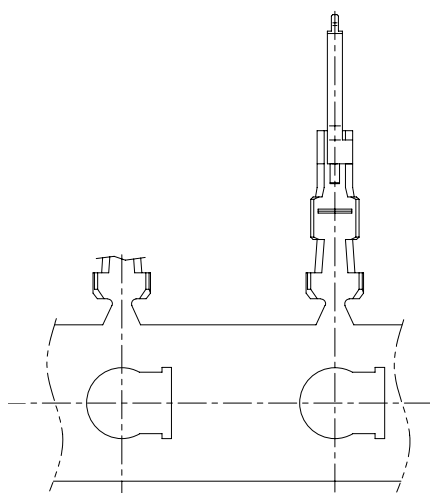

DETAIL A
 A部詳細図
 (SCALE 10:1)
 (尺度 10:1)

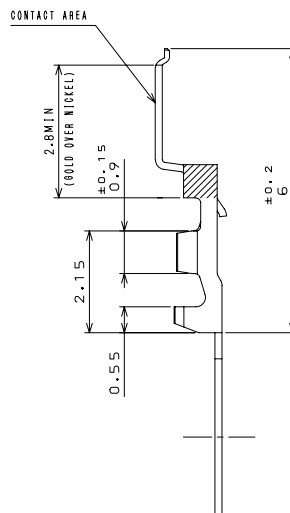

Ordering Information

Lower Contact for Crimp Housing (SJ103061)

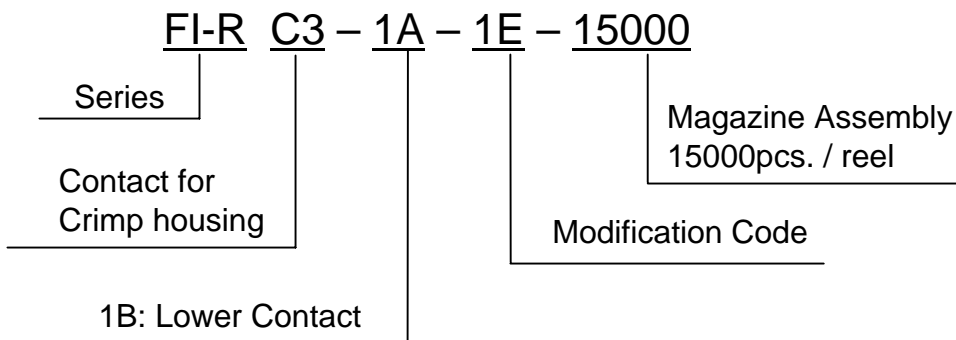

B3

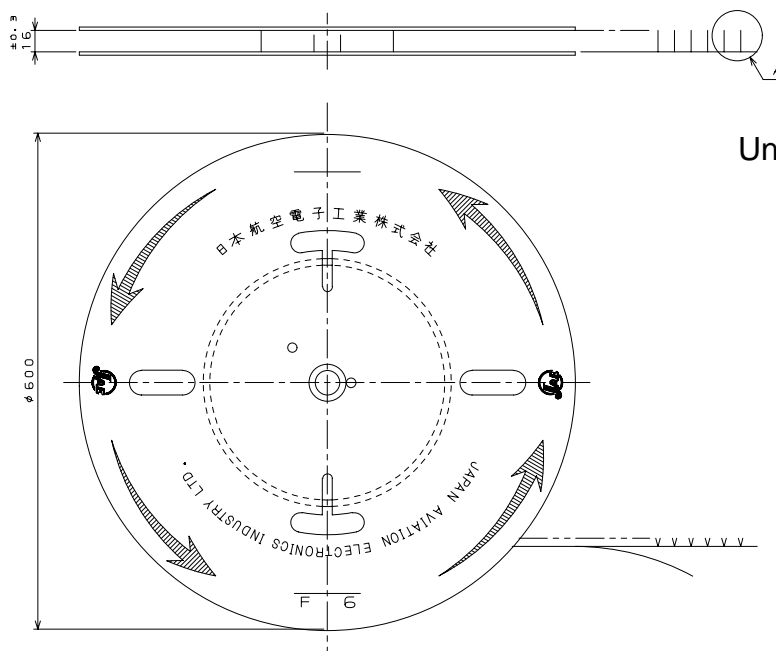

Unit: mm



EXCLUDING CRIMP POT
 クリンプポット部は除く

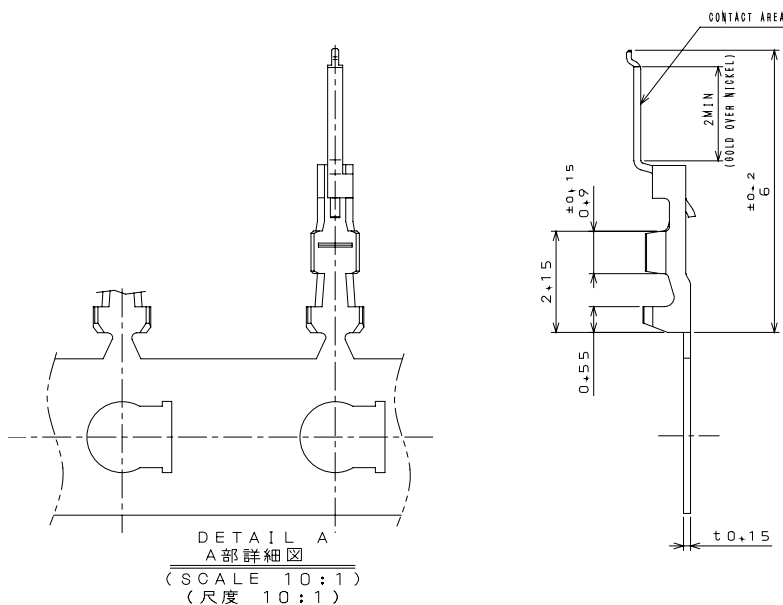

Ordering Information

Plug, Solder Type (Lock, shell type)
(SJ104311)

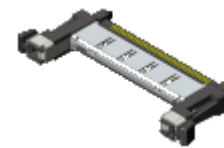
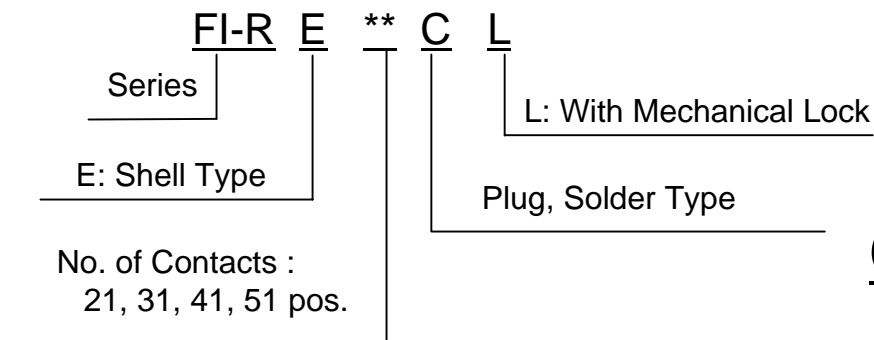

C1

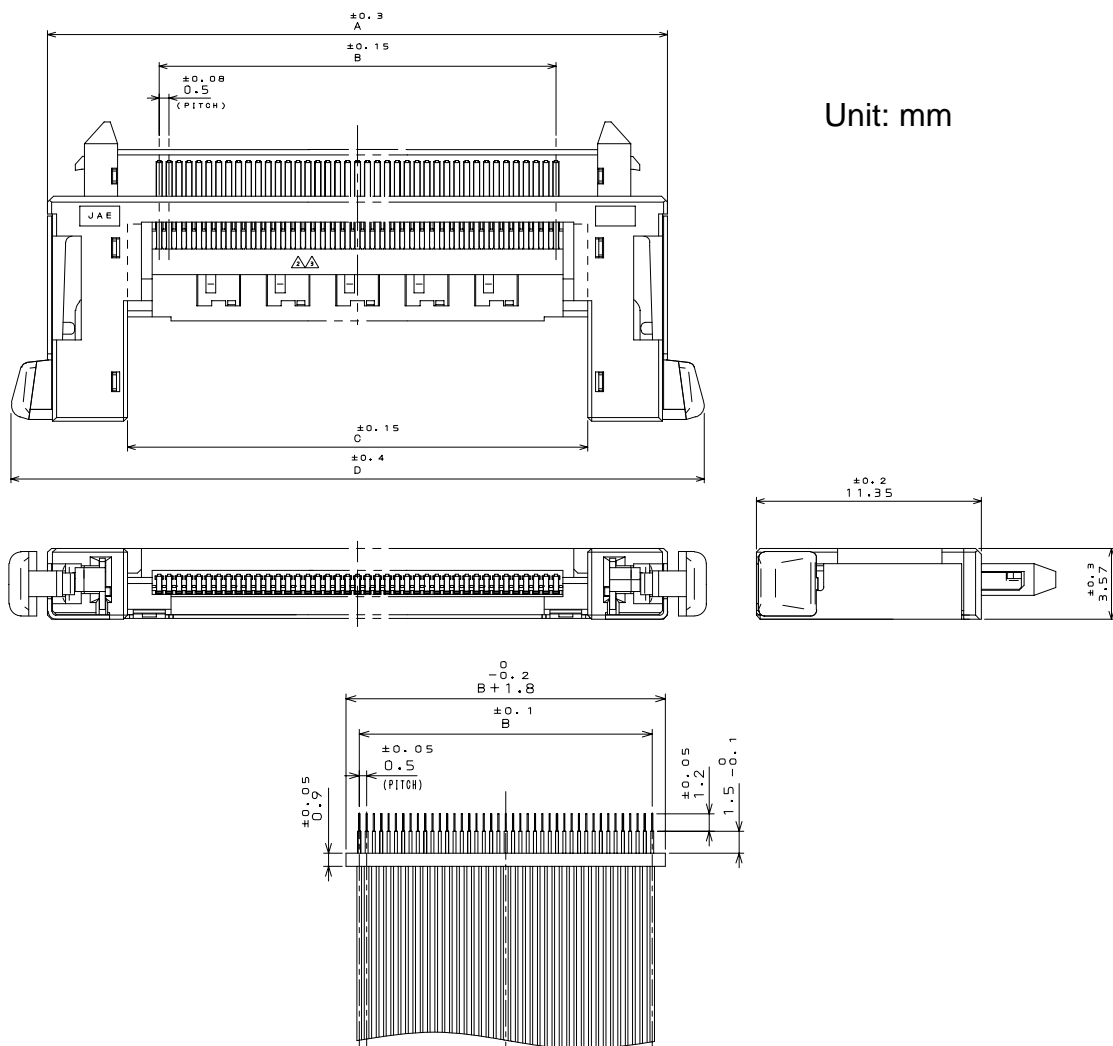

Drawing when cable is connected (for reference)

Dimensions

NO. OF CONTACTS (N)	A	B	C	D
21	21.25	10.0	13.2	24.95
31	26.25	15.0	18.2	29.95
41	31.25	20.0	23.2	34.95
51	36.25	25.0	28.2	39.95

Ordering Information

Cover Shell for Solder Type (SJ104716)

FI-R E ** C L - SH2 - 3000
 Series
 E: Shell Type
 No. of Contacts :
 21, 31, 41, 51 pos.
 Embossed Tape
 3000pcs. per reel
 Cover Shell
 L: With Mechanical Lock
C2
 Plug Solder Type



Unit: mm

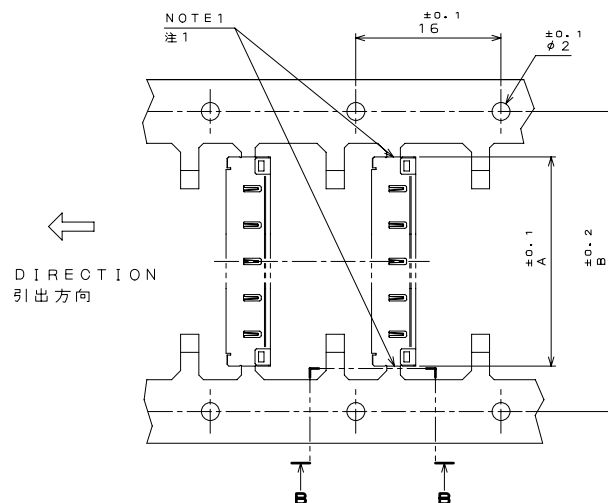
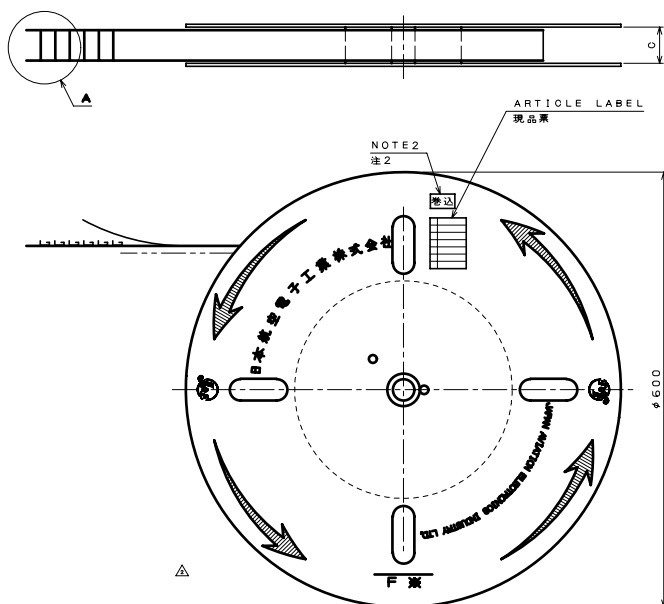

Dimensions

NO. OF CONTACT 芯数	A	B	C
21	13.0	19.0	26.0
31	18.0	28.0	40.0
41	23.0	35.0	50.0
51	28.0	34.0	40.0



DETAIL A
 A部詳細図
 (SCALE 2:1)
 (尺度 2:1)

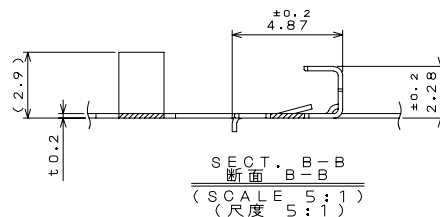

Lineup

Receptacle



Number of Contacts	Type	Mounting Direction	Part Number	Reel Part Number
21	Shell	Right-angle	FI-RE21S-HF	FI-RE21S-HF-R1500
		Straight	FI-RE21S-VF	FI-RE21S-VF-R1300
31	Shell	Right-angle	FI-RE31S-HF	FI-RE31S-HF-R1500
		Straight	FI-RE31S-VF	FI-RE31S-VF-R1300
41	Shell	Right-angle	FI-RE41S-HF	FI-RE41S-HF-R1500
		Straight	FI-RE41S-VF	FI-RE41S-VF-R1300
51	Shell	Right-angle	FI-RE51S-HF	FI-RE51S-HF-R1500
		Straight	FI-RE51S-VF	FI-RE51S-VF-R1300

Plug, Crimp Type



Number of Contacts	Type	Mechanical Lock	Part Number
21	Shell	Yes	FI-RE21HL
31	Shell	Yes	FI-RE31HL
41	Shell	Yes	FI-RE41HL
51	Shell	Yes	FI-RE51HL

Plug, Solder Type

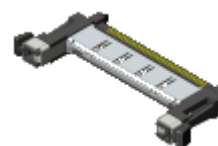

Number of Contacts	Type	Mechanical Lock	Part Number	Cover Shell Part Number
21	Shell	Yes	FI-RE21CL	FI-RE21CL-SH2-3000
31			FI-RE31CL	FI-RE31CL-SH2-3000
41			FI-RE41CL	FI-RE41CL-SH2-3000
51			FI-RE51CL	FI-RE51CL-SH2-3000

Related Documents

• Contact Crimp Tool (Manual)

Part Number: CT150-4C-FIR
Handling Instruction: T700276

• Contact Crimp Tool (Semi-automatic machine)

Press Machine

Part Number: CT215-4B
Handling Instruction: T707064

Applicator

Part Number: 350-FI-2B
Handling Instruction: T703263**Japan Aviation Electronics Industry, Limited**Product Marketing Division
Aobadai Building, 3-1-19, Aobadai, Meguro-ku, Tokyo 153-8539
Phone: +81-3-3780-2787 FAX: +81-3-3780-2946

Notice: Products shown in this leaflet are made for the applications listed below. However, if the above-mentioned products are to be used in aerospace devices, marine cable-connection devices, atomic power control systems, medical equipment for life-support systems, and any other specific application requiring extremely high reliability, please contact JAE for further information.

Recommended applications: Computers, Office machines, Measuring devices, Telecommunication devices (Terminals, Mobile devices), AV devices, Household applications, FA devices, etc.