

TFlum

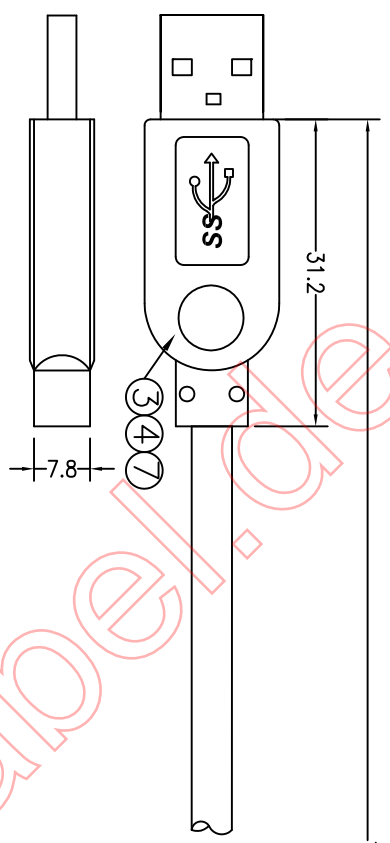

USB3.0 AM(Nickel plated)
BLACK MOLDING
TOOLING NO:488

ITEM NO	Length(mm)	Tolerance(mm)
USB3-AF-AM-300	300	10
USB3-AF-AM-500	500	15
USB3-AF-AM-600	600	15
USB3-AF-AM-900	900	20

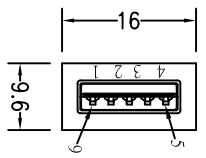
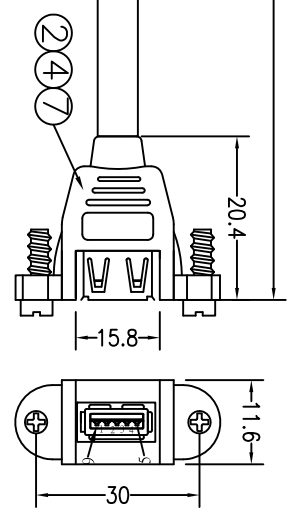
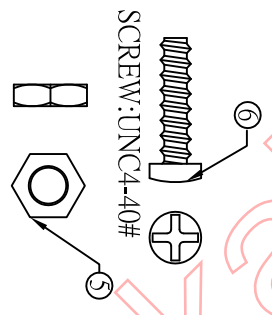

USB3.0 AF(NICKEL PLATED)
BLUE MOLDING:691
TOL:±0.5

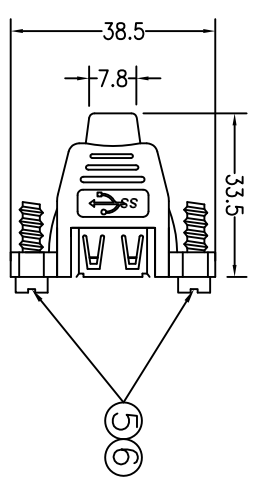

PIN ASSIGNMENT:

USB AM	1	2	3	4	5	6	7	8	9	64
USB AF	1	2	3	4	5	6	7	8	9	64
					TP		GND	GND	TP	BRAID

HEX-NUT: #4-40(4.75*1.9mm)

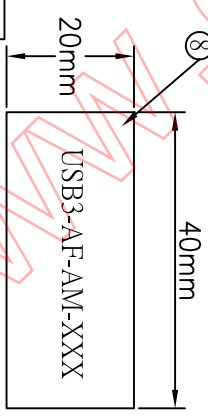

Stickers

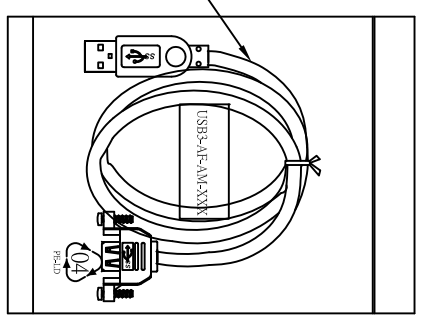

⑨	PE BAG(0.06*190*300mm)	1PCS
⑧	Stickers(40*20mm)	1PCS
⑦	PE	10g
⑥	SCREW:UNC4-40#	2PCS
⑤	HEX-NUT: #4-40(4.75*1.9mm)	2PCS
④	BLUE 45P PVC	10g
③	USB AM 3.0 (BLUE INSULATOR,Nickel plated)	1PCS
②	USB AF 3.0 (BLUE INSULATOR,Nickel plated)	1PCS
①	UL2725, 30#/28#24 AL+B(AM),OD=5.5mm,BLUE COLOR,PVC JACKET.	1PCS

No.	Description	Qty
	OPEN/SHORT TEST: 100% TEST. INSULATION: 5M.	
	1PCS/PE BAG(0.06*190*300mm)+Stickers	

Company	Goods Code	Draw	Date	2013.01.07
ITEM NO.	Drawing Evidence	Check	Date	
Goods NO.	USB3-AF-AM-XXX	Approval	Date	
Original NO.	Unit(mm)	Approval	Date	
				D C B VER. A REVISE Date