

USB 3.1 CM(Nickel Plated)  
Black Molding,NO:1825  
TOL:±0.3

USB3.1CF(Nickel Plated)  
Black Molding,No:1683  
TOL:±0.3

**PIN ASSIGNMENT:**

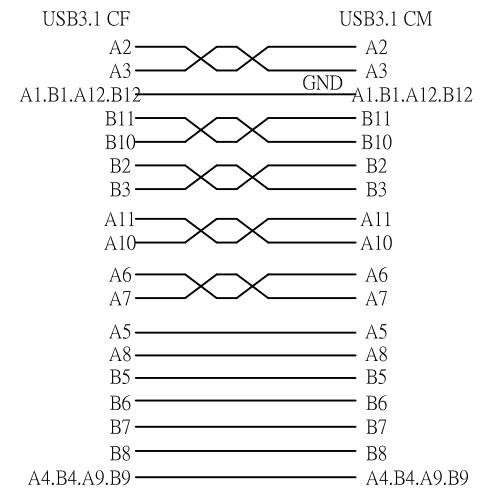

MAX 10GB,3A to Cable  
GEN2

OPEN/SHORT TEST:100% TEST.  
INSULATION: MIN. 5M.

KAB-USB3.1-CM-USB3.1-CF-PANEL-0900RK

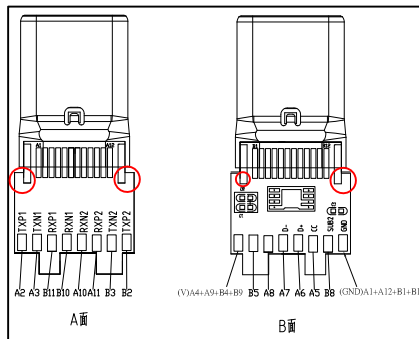

|     |   |      |
|-----|---|------|
| ⑦   | Hex Nuts : #4-40(4.75*1.9mm)  | 2PCS |
| ⑥   | USB3.1 CF(Black Insulator,Nickel Plated),16PIN  | 1PCS |
| ⑤   | Copper foil   | 2PCS |
| ④   | PE  | 10g  |
| ③   | Black 45P PVC   | 20g  |
| ②   | USB3.1 CM Type(Black Insulator,Nickel Plated),16PIN   | 1PCS |
| ①   | UL-2725 1/0.2T*1P+AL+MY)*4C+(1/0.16T*1P)*2C+1/0.2T*4C+41/0.08T*2C+D+AL OD=4.8MM Black PVC Jacket. | 1PCS |
| No. | Description   | Qty  |

|              |                  |                  |  |          |     |      |            |
|--------------|------------------|------------------|--|----------|-----|------|------------|
| Company      |                  | Goods Code       |  | Draw     | OYH | Date | 2019.05.04 |
| ITEM NO.     | USB3-CM-CF-3FT-C | Drawing Evidence |  | Check    |     | Date |            |
| Goods NO.    |                  |                  |  | Approval |     | Date |            |
| Original NO. |                  | Unit(mm)         |  | Audit    |     |      |            |



|        |        |      |
|--------|--------|------|
| D      |        |      |
| C      |        |      |
| B      |        |      |
| VER. A | REVISE | Date |