

Mating condition section (Scale 30:1)

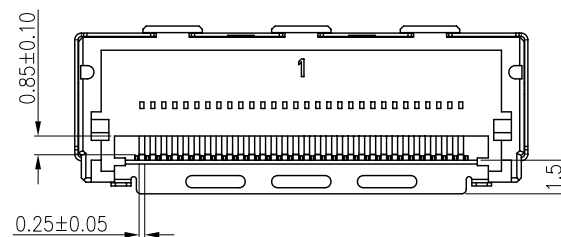
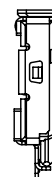
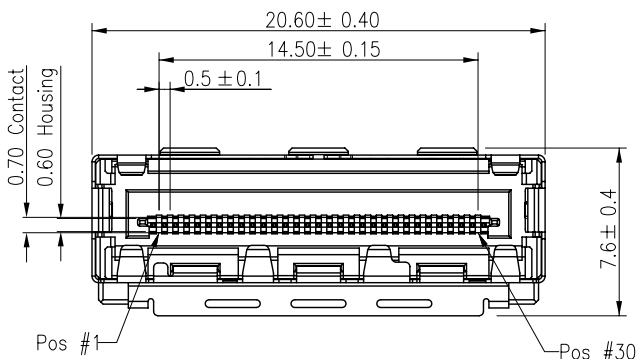
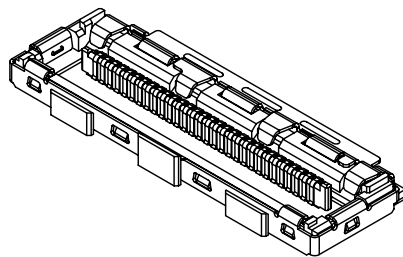
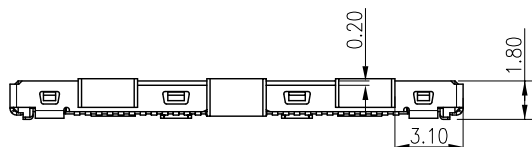

30 Pin

NOTES:

1. MATERIAL:
 - 1.1 HOUSING: THERMOPLASTIC, HIGH TEMP., UL94V-0; COLOR:BLACK.
 - 1.2 CONTACT: COPPER ALLOY
 - 1.3 UPPER SHELL: COPPER ALLOY
2. FINISH:
 - CONTACT: SEE ORDER INFORMATION
 - UNDERPLATING: 50~100u" NICKEL OVERALL.
3. REFLOW SOLDER CAPABLE TO 260°C PER ACES SPEC.
4. SPEC. PLS. REFER TO PS-50398-xxxxx
5. PACKAGE PLS. REFER TO 50399-TB
6. PART NUMBER
 - 50399-XXX X X-XXX
 - 030.30Pin
 - PACKING
 - 1.TUBE
 - METAL SHELL PLATING
 - 001: SOLDERABLE NICKEL OVER ALL.
 - 002: TIN PLATDE OVER ALL.
 - CONTACT PLATING
 - 1: 3u" GOLD ON CONTACT FOR LEAD FREE
 - T: 10u" GOLD ON CONTACT FOR LEAD FREE
 - C: 15u" GOLD ON CONTACT FOR LEAD FREE
 - B: 5u" GOLD ON CONTACT FOR LEAD FREE
7. APPLICABLE CABLE
 - COAXIAL CABLE AWG#36~42
 - DISCRETE WIRE AWG#32
 - TEFLON WIRE AWG#34
 - INSULATION O.D: 0.4mm Max.
8. MATING CONNECTOR
 - P/N: 50406

一般公差 TOLERANCES X ±0.5 XX ±0.15 X ±0.25 .XXX ±0.1 ANGLES ±2°		宏致電子股份有限公司 Aces Electronics Co.,Ltd.			
檢驗尺寸標示 SYMBOLS INDICATE CLASSIFICATION DIMENSION MARK IS CRITICAL DIM. MARK IS MAJOR DIM.	品名 (TITLE) 0.5 Pitch WTB LVDS CONN. Plug Type	製圖 (DR) 14/08/18 JUGG	審核 (CHKD) DAVID	核准 (APPD) FRANK	
圖號 (DWG NO.) 50399-XXXXX-XXX	比例 (SCALE) 2:1	單位 (UNITS) mm		張數 (SHEET) 1 OF 6	SIZE A4
表面處理 (FINISH)					REV L

A B C D E F

1

2

3

4

5

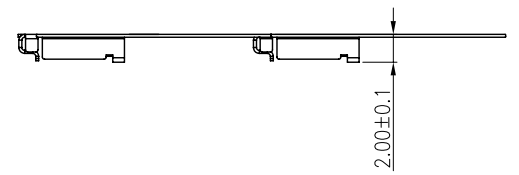
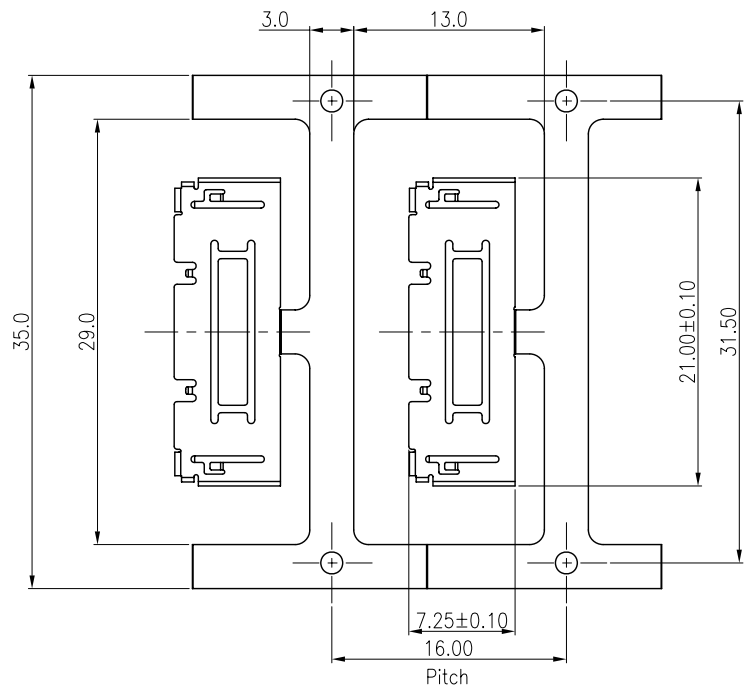

NOTES:

1. MATERIAL:SUS,THICKNESS 0.20±0.01mm
2. PLATING
 V.ALL UNDERPLATED 30u"~100u" DUCTILE NICKEL
 L.ALL UNDERPLATED 30u"~100u" DUCTILE NICKEL
 30-80u" TIN PLATED OVER ALL
3. PART NUMBER

50399-M 8 X X -030

MATERIAL 5.SUS304 PLATED
 V.Solderable Nickel over all
 L:TIN PLATDE OVER ALL.

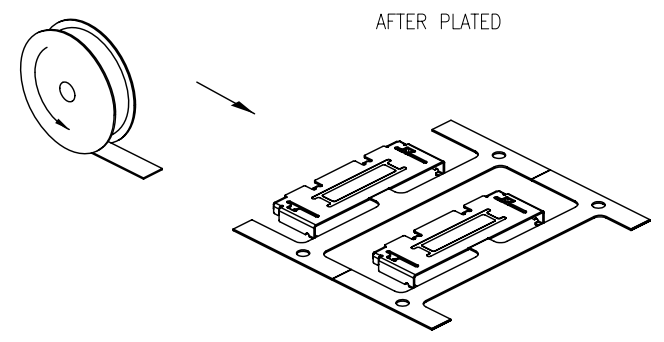

30 Pin

A B C D E F

一般公差 TOLERANCES X ±0.5 .XX ±0.15 X ±0.25 .XXX ±0.1 ANGLES ±2°		宏致電子股份有限公司 Aces Electronics Co.,Ltd.	
檢驗尺寸標示 SYMBOLS INDICATE CLASSIFICATION DIMENSION MARK IS CRITICAL DIM. MARK IS MAJOR DIM.		品名 (TITLE) 0.5 Pitch WTBLVDS CONN. Plug Type	製圖 (DR) 14'/08/18 JUGG 審核 (CHKD) DAVID
		圖號 (DWG NO.) 50399-XXXXX-XXX	核准 (APPD) FRANK
表面處理 (FINISH)	比例 (SCALE) 2:1	單位 (UNITS) mm	張數 (SHEET) 2 OF 6 SIZE A4 REV L



A | B | C | D | E | F

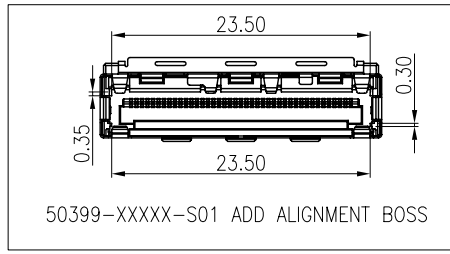
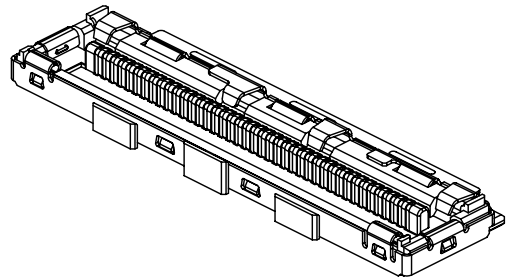

- NOTES:
- MATERIAL:
 - HOUSING: THERMOPLASTIC, HIGH TEMP., UL94V-0; COLOR:BLACK.
 - CONTACT: COPPER ALLOY
 - UPPER SHELL: COPPER ALLOY
 - FINISH:
 - CONTACT: SEE ORDER INFORMATION.
 - UNDERPLATING: 50~100u" NICKEL OVERALL.
 - REFLOW SOLDER CAPABLE TO 260°C PER ACES SPEC.
 - SPEC. PLS. REFER TO PS-50398-xxxxx
 - PACKAGE PLS. REFER TO 50399-TB
 - PART NUMBER

50399-XXX X X-XXX

040:40Pin	METAL SHELL PLATING
PACKING	001:SOLDERABLE NICKEL OVER ALL.
	002:TIN PLATDE OVER ALL.
	S01:ADD ALIGNMENT BOSS
1.TUBE	003: MATTE TIN PLATDE OVER ALL.
2.TRAY	

CONTACT PLATING

1.3u" GOLD ON CONTACT FOR LEAD FREE

T.10u" GOLD ON CONTACT FOR LEAD FREE

C.15u" GOLD ON CONTACT FOR LEAD FREE

B.5u" GOLD ON CONTACT FOR LEAD FREE
 - APPLICABLE CABLE
 - COAXIAL CABLE AWG#36~42
 - DISCRETE WIRE AWG#32
 - TEFLON WIRE AWG#34
 - INSULATION O.D:0.4mm Max.
 - MATING CONNECTOR

P/N:50398

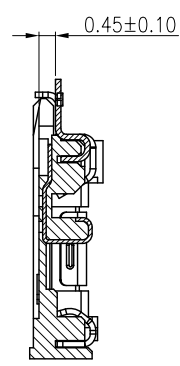

Section A-A
Scale 5

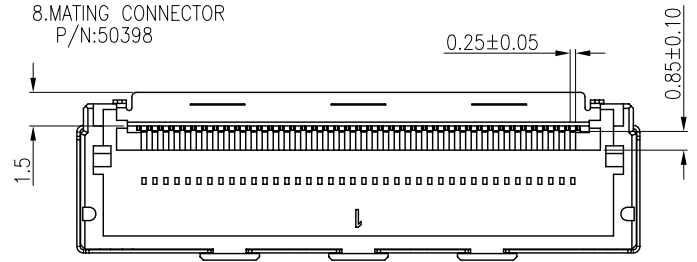
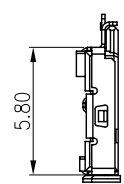
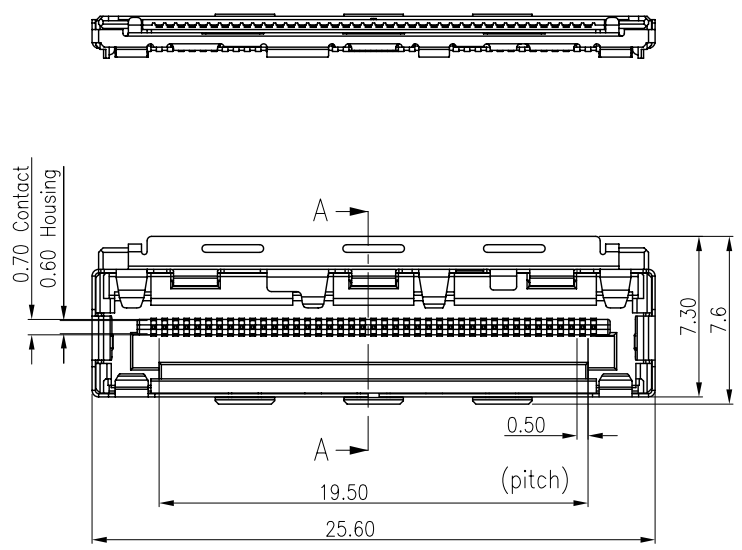

40 Pin

A | B | C | D | E | F

一般公差 TOLERANCES X ±0.5 XX ±0.15 X ±0.25 .XXX ±0.1 ANGLES ±2°		宏致電子股份有限公司 Aces Electronics Co.,Ltd.	
檢驗尺寸標示 SYMBOLS INDICATE CLASSIFICATION DIMENSION MARK IS CRITICAL DIM. MARK IS MAJOR DIM.	品名 (TITLE) 0.5 Pitch WTB LVDS CONN. Plug Type	製圖 (DR) 14'/08/18 JUGG	審核 (CHKD) DAVID
	圖號 (DWG NO.) 50399-XXXX-XXX	核准 (APPD) FRANK	
表面處理 (FINISH)	比例 (SCALE) 2:1	單位 (UNITS) mm	張數 (SHEET) 3 OF 6 SIZE A4 REV L

A B C D E F

1

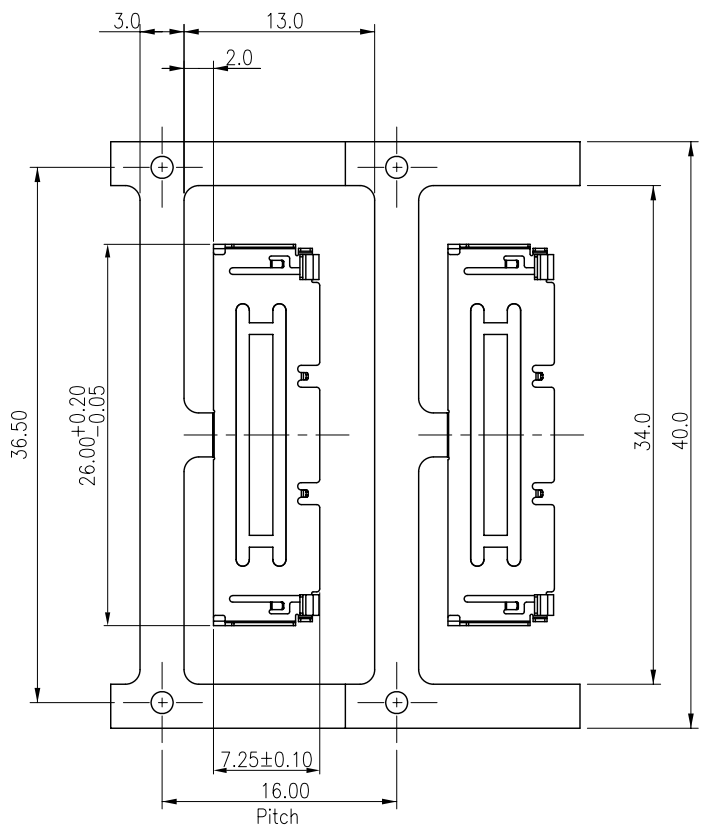

- NOTES:
1. MATERIAL:SUS,THICKNESS 0.20±0.01mm
 2. PLATING
 V.ALL UNDERPLATED 30u"~100u" DUCTILE NICKEL
 L.ALL UNDERPLATED 30u"~100u" DUCTILE NICKEL
 30-80u" TIN PLATED ALL
 N.ALL UNDERPLATED 30u"~100u" DUCTILE NICKEL
 80-120u" MATTE TIN PLATED ALL
 3. PART NUMBER

50399-M 8 X X -040

MATERIAL 5.SUS304 PLATED
 V.Solderable Nickel over all
 L:TIN PLATDE OVER ALL.
 N.MATTE TIN

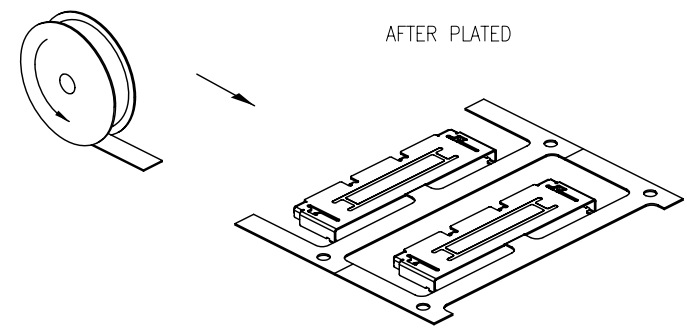

40 Pin

3

5

A B C D E F

一般公差 TOLERANCES X ±0.5 .XX ±0.15 X ±0.25 .XXX ±0.1 ANGLES ±2°		宏致電子股份有限公司 Aces Electronics Co.,Ltd.	
檢驗尺寸標示 SYMBOLS INDICATE CLASSIFICATION DIMENSION	品名 (TITLE) 0.5 Pitch WTBLVDS CONN. Plug Type	製圖 (DR) 14'/08/18 JUGG	審核 (CHKD) DAVID
MARK IS CRITICAL DIM. MARK IS MAJOR DIM.	圖號 (DWG NO.) 50399-XXXXX-XXX	核准 (APPD) FRANK	
表面處理 (FINISH)	比例 (SCALE) 2:1	單位 (UNITS) mm	張數 (SHEET) 4 OF 6
			SIZE A4
			REV L

1

2

3

4

5



A B C D E F

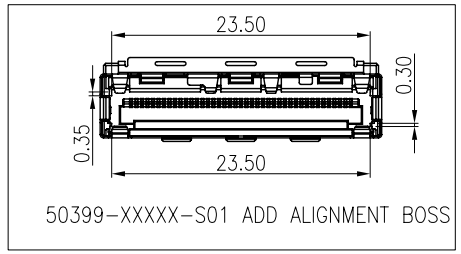
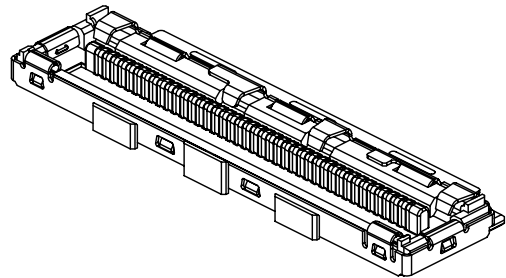

- NOTES:
- MATERIAL:
 - HOUSING: THERMOPLASTIC, HIGH TEMP., UL94V-0; COLOR:BLACK.
 - CONTACT: COPPER ALLOY
 - UPPER SHELL: COPPER ALLOY
 - FINISH:

CONTACT: SEE ORDER INFORMATION.

UNDERPLATING: 50~100u" NICKEL OVERALL.
 - REFLOW SOLDER CAPABLE TO 260°C PER ACES SPEC.
 - SPEC. PLS. REFER TO PS-50398-xxxx
 - PACKAGE PLS. REFER TO 50399-TB
 - PART NUMBER

50399-XXX X X-XXX

050:50Pin	METAL SHELL PLATING
PACKING	001:SOLDERABLE NICKEL OVER ALL.
1.TUBE	002:TIN PLATDE OVER ALL.
2.TRAY	S01:ADD ALIGNMENT BOSS

CONTACT PLATING

1.3u" GOLD ON CONTACT FOR LEAD FREE

T.10u" GOLD ON CONTACT FOR LEAD FREE

C.15u" GOLD ON CONTACT FOR LEAD FREE

B.5u" GOLD ON CONTACT FOR LEAD FREE
 - APPLICABLE CABLE

COAXIAL CABLE AWG#36~42

DISCRETE WIRE AWG#32

TEFLON WIRE AWG#34

INSULATION O.D.:0.4mm Max.
 - MATING CONNECTOR

P/N:50398

0.45±0.10

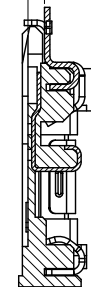
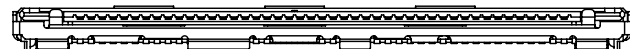

0.70 Contact
0.60 Housing

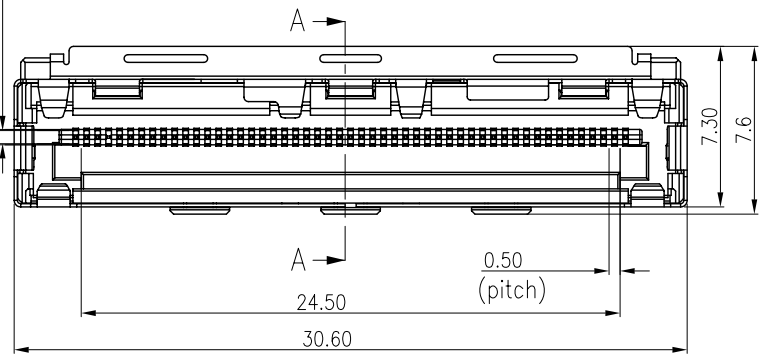

Section A-A
Scale 5

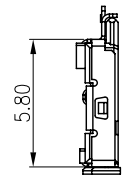

5.80

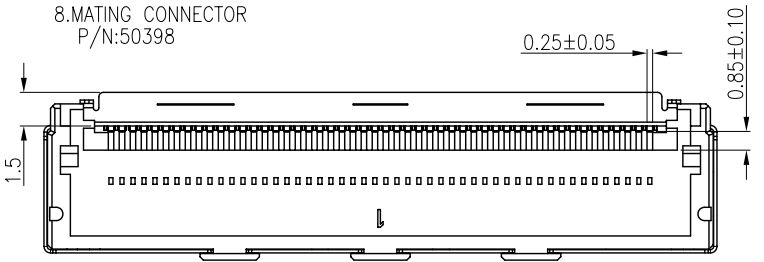

50 Pin

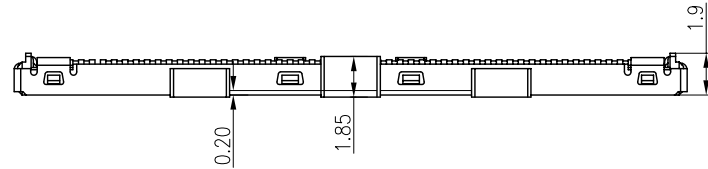

A B C D E F

一般公差 TOLERANCES X ±0.5 XX ±0.15 X ±0.25 .XXX ±0.1 ANGLES ±2°		宏致電子股份有限公司 Aces Electronics Co.,Ltd.	
檢驗尺寸標示 SYMBOLS INDICATE CLASSIFICATION DIMENSION MARK IS CRITICAL DIM. MARK IS MAJOR DIM.	品名 (TITLE) 0.5 Pitch WTB LVDS CONN. Plug Type	製圖 (DR) 14'/08/18 JUGG	審核 (CHKD) DAVID
	圖號 (DWG NO.) 50399-XXXX-XXX	核准 (APPD) FRANK	
表面處理 (FINISH)	比例 (SCALE) 2:1	單位 (UNITS) mm	張數 (SHEET) 5 OF 6
			SIZE REV A4 L

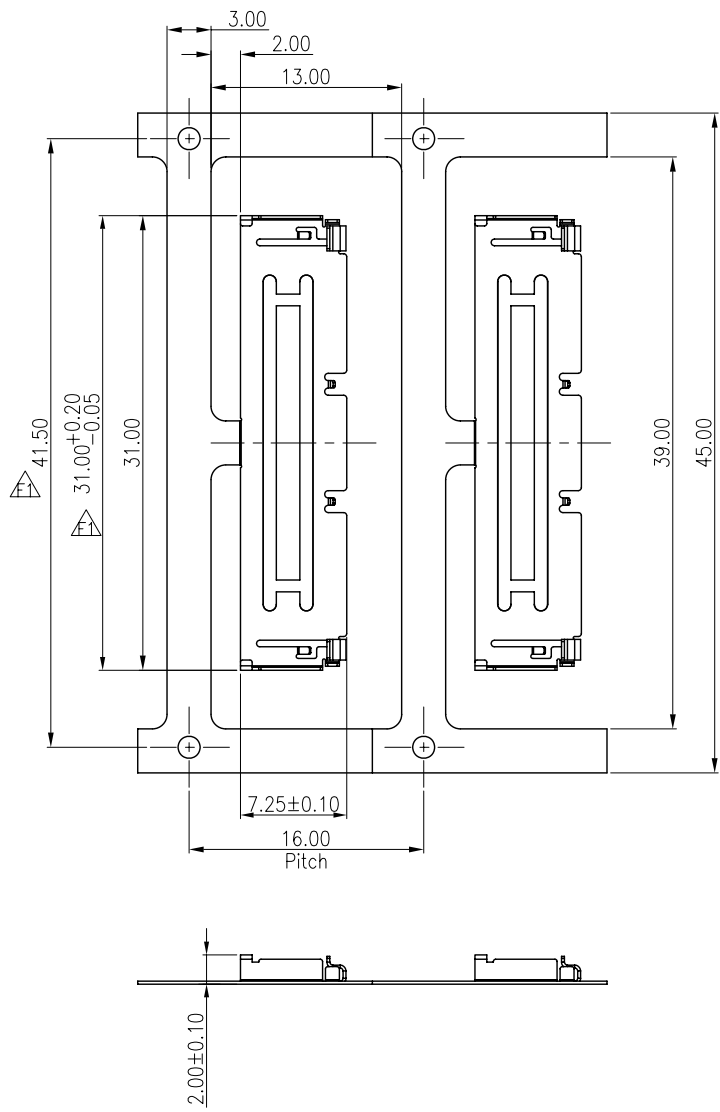

NOTES:
 1. MATERIAL:SUS,THICKNESS 0.20±0.01mm
 2. PLATING
 V.ALL UNDERPLATED 30u"~100u" DUCTILE NICKEL
 L.ALL UNDERPLATED 30"~100u" DUCTILE NICKEL
 30-80u" TIN PLATED ALL
 3. PART NUMBER

50399-M 8 X X -050
 MATERIAL 5.SUS304 PLATED
 V.Solderable Nickel over all
 L:TIN PLATDE OVER ALL.

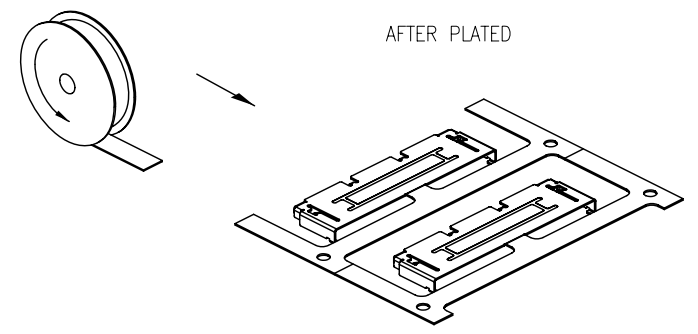

50 Pin

一般公差 TOLERANCES X ±0.5 XX ±0.15 X ±0.25 .XXX ±0.1 ANGLES ±2°		宏致電子股份有限公司 Aces Electronics Co.,Ltd.	
檢驗尺寸標示 SYMBOLS INDICATE CLASSIFICATION DIMENSION	品名 (TITLE) 0.5 Pitch WTBLVDS CONN. Plug Type	製圖 (DR) 14'/08/18 JUGG	審核 (CHKD) DAVID
MARK IS CRITICAL DIM. MARK IS MAJOR DIM.	圖號 (DWG NO.) 50399-XXXXX-XXX	核准 (APPD) FRANK	
表面處理 (FINISH)	比例 (SCALE) 2:1	單位 (UNITS) mm	
		張數 (SHEET) 6 OF 6	SIZE A4
			REV L